



EBSILON[®]*Professional*

The Planning Tool for the Power Plant Process

Join the future
Join the expert family



Please allow us to introduce ourselves: STEAG Energy Services GmbH

STEAG GmbH, the parent company of STEAG Energy Services GmbH, has been active in the field of power generation for almost 75 years. As a company with international operations, STEAG offers its customers integrated solutions in the fields of power and heat generation as well as technical services.

The engineers at STEAG Energy Services GmbH develop comprehensive professional engineering solutions for all areas of electricity generation.

With our services in the field of energy we make sure that a power plant operates reliably in terms of technology, organization, economic efficiency, and environmental protection.

Here our customers benefit from our experience of many years and the competencies we have acquired at our own power plants.

Our subsidiaries in India, Brazil, Turkey, Switzerland, and the USA contribute to this.

For over 20 years, we have been developing and marketing software for use in the power industry. With the right software, a lot of processes can be controlled efficiently – from planning via operation right up to maintenance.

Our worldwide references confirm the excellent quality and the economic benefit.

EBSILON®Professional: Well-Engineered and Future-Proof

EBSILON®Professional has been developed further systematically for more than 20 years. The first version was introduced by Sofbid GmbH in 1990. Since the merger of Sofbid with STEAG GmbH in 2006, **EBSILON®Professional** has been an important product in the portfolio of STEAG System Technologies.

In more than two decades, **EBSILON®Professional** has been continuously optimized with features like the intuitive graphical user interface, the data validation, and a lot of component libraries and material libraries as well as additional modules.

In the course of this, we do not exclusively draw on the know-how of our engineers, who deal with the challenges

of power plant technology in the STEAG power plants and the power plants of our customers on a daily basis. Also our cooperation partners' experience plays an important part. Among the most important cooperation partners are e.g. the German Aerospace Center (DLR), the company VTU Energy, and universities like TU Darmstadt and University of Applied Sciences Zittau/Görlitz.

Last but not least, our customers' requirements and wishes are a major motivation for the current and future development of our software. The dialog with our users is one of the principles of the success of **EBSILON®Professional**. As a member of the **EBSILON®Professional** expert team, you can be sure at all times that your software tool stays up-to-date and effective.



EBSILON[®]*Professional*

The Planning Tool for the Power Plant Process

EBSILON[®]*Professional* is a simulation system for thermodynamic cycle processes that is used for plant planning, design and optimization. Maximize the benefits of repowering and retrofitting measures by simulating them in **EBSILON**[®]*Professional*. Design a performance-optimized plant for your application scenario by introducing specific parameters into the model. Calculate the effects of component degradation, various load cases and changes in environmental conditions. Simulate the operation of newly developed components in a cycle.

Precise planning is the basis for a successful implementation of the project, both in the construction and in the modification of energy and power plant systems. It has to be analyzed early on whether and how the performance requirements can be achieved.

EBSILON[®]*Professional* supports you in the planning, from the feasibility study right up to the detailed design of the plant.

Owing to the high flexibility of the system and the universality of the approach, any thermodynamic cycle can be modeled.

From conventional power plants, nuclear and solar power plants right up to desalination plants, fuel cell applications as well as user-specific processes, there are no limits to the modeling options.

*"With **EBSILON**® Professional I work intuitively and with a universal calculation approach. The solution algorithm is just perfect. It simply converges."*

Join the future
Join the expert family





EBSILON®Professional

Optimal Planning, Optimal Operation

Modeling your plant in **EBSILON®Professional** proves to be intuitive and comfortable due to the Windows-based graphical user interface.

By means of the component library of **EBSILON®Professional** you map the topology of your cycle in a precise way.

The universal calculation approach and the powerful solution algorithm ensure a fast and reliable calculation of the system parameters.

An intelligent error analysis and the comprehensive online help assist the user in the modeling.

- Intuitive modeling with graphical user interface
- Powerful calculation kernel and solution algorithm
- Comprehensive component library
- Material data libraries for working fluids and fuels
- Comfortable analysis and presentation of results
- Open software architecture and powerful interfaces
- Intelligent error analysis and online help
- Expansion of the functionality by means of add-on modules

"It is quite easy to visualize everything already in the planning phase. With the component library and the fluid libraries, I can model the cycle quickly and precisely."

Join the future
Join the expert family



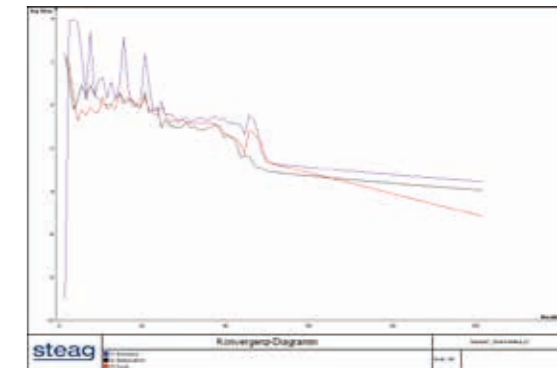
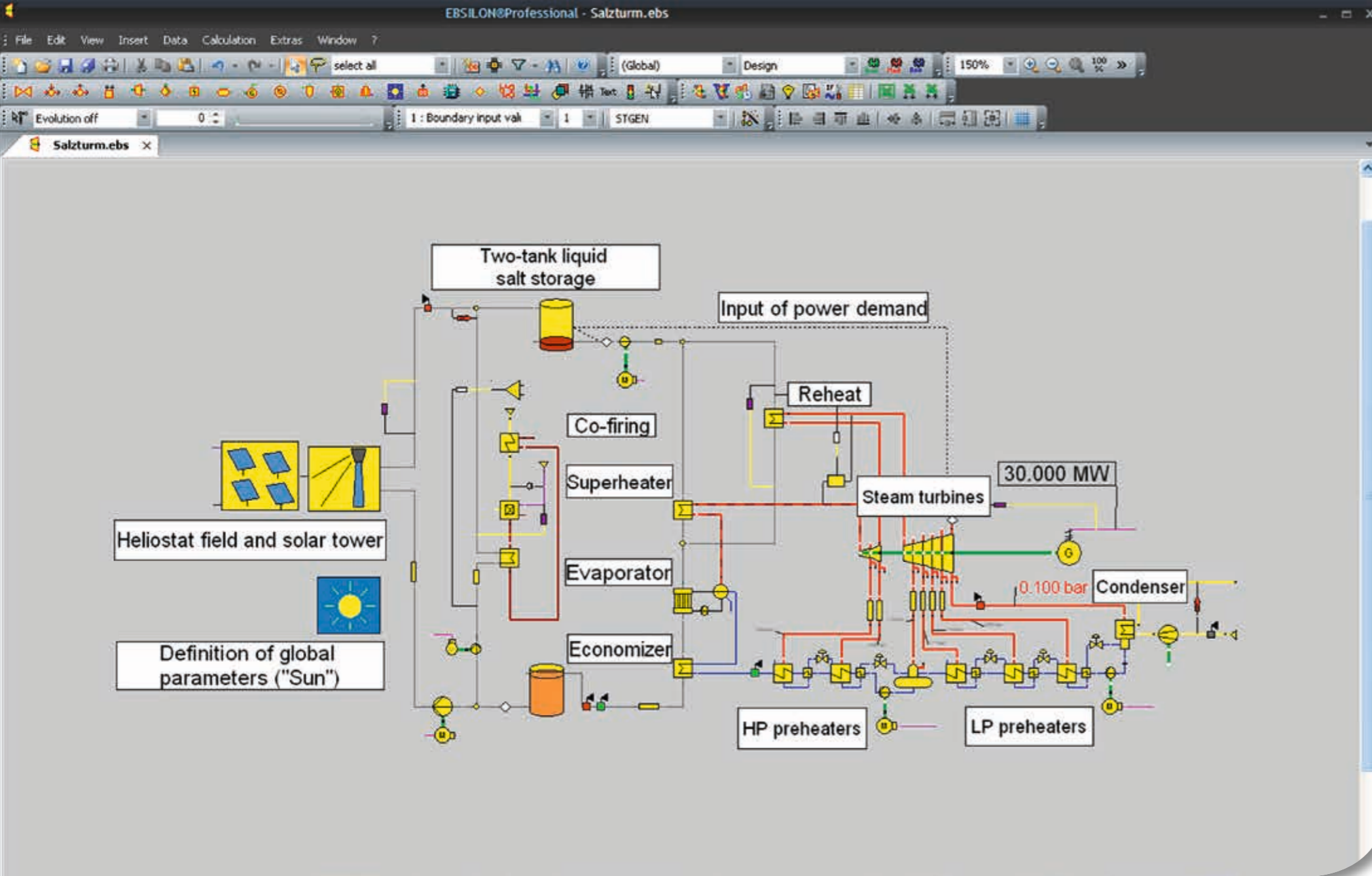

Graphical User Interface – Intuitive Operation & Easy to Customize

EBSILON[®]Professional is operated via a Windows-based graphical user interface, which distinguishes itself by its high operating comfort and its adaptability to your demands.

To map the topology of the plant, the components of the cycle are arranged by drag and drop and connected with logic and material lines.

- Parallel display of models in tabs
- User-defined macros
- Tools for selecting, zooming as well as manipulating components like resize, rotate, mirror
- Customizable display and design of components
- User-defined keyboard shortcuts
- Graphical elements for improving the clear arrangement of the model
- Operation in German, English, French, Spanish, Turkish and Chinese

Solution Algorithm – Fast & Powerful

EBSILON[®]Professional's highly efficient calculation kernel allows the detailed simulation of complex applications, like e.g. the district heating system of a city. The exceptional speed and convergence reliability of the algorithm ensure a correct calculation of the cycle in the steady state.

Release 10 and higher offer the possibility of transient calculations. Convergence and controller diagrams as well as statistical characteristics help to quantify and improve the convergence behavior.

- Fast simulation result:
Calculate a model with 1,100 components and 1,400 lines in only 2.5 seconds
- Convergence analysis tools:
Convergence and controller diagrams
- Twenty years of successful application and further development

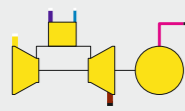

Gas turbine

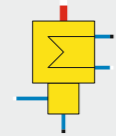

Condenser



Steam turbine

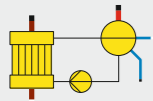

Evaporator with drum

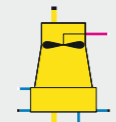

Forced draft cooling tower

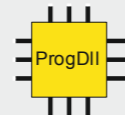

Programmable component



Generator

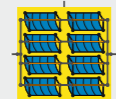

Solar field

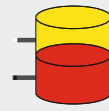

Mass storage

The Component Library – Simulation of your Plant

The component library of **EBSILON[®]Professional** contains components both for all typical power plant processes and for specific applications like desalination plants, solar power plants, chiller or fuel cell applications.

The components are adjusted to the actual performance behavior by means of parameters and characteristics. The modeling options can be expanded as required with the help of programmable components.

Continuous maintenance and further development of the component library ensure that at all times the latest technical applications can be modeled in **EBSILON[®]Professional**.

Physical components

- Pumps
- Turbines
- Steam generators
- Condensers
- Heat exchangers
- Cooling towers
- Filters
- Etc.

Logic components

- Controllers
- Signal transformers
- Calculation modules
- Efficiency meters
- Etc.

User-defined components

- Kernel scripting
- DLL-programmable component

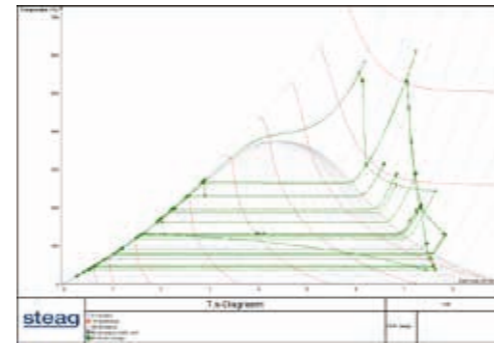

Processes in T-s diagram



Report in MS Excel

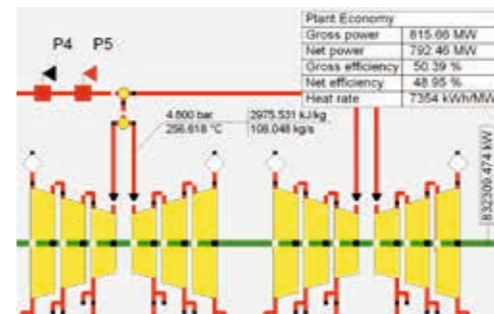

Value crosses and text fields in the model

Display and Analysis of Results

EBSILON[®]Professional offers numerous ways to display the results of the simulations. These include text fields and value crosses for displaying the results in the model as well as the representation of the processes in state diagrams.

Export to MS Excel allows to further process the simulation results easily.

- Value crosses, text and alarm fields in the model
- Simulation reports in MS Excel
- State diagrams: Q-T, h-s, h-x₁, T-s, log(p)-h
- Convergence and controller diagrams
- User defined diagrams in MS Excel

Error Analysis and Online Help

Intelligent error analysis

During the simulation, modeling errors are localized by the integrated error analysis, and the user is informed about their causes.

Online help

The online help provides detailed information on the features of **EBSILON[®]Professional** and the add-on modules. The design and physical mode of operation of components are explained to the user, and sample models are supplied.

*"I cannot afford mistakes. The comfortable presentation of results and the intelligent error analysis make sure that with **EBSILON**[®]Professional, everything becomes transparent and manageable."*

Join the future

Join the expert family

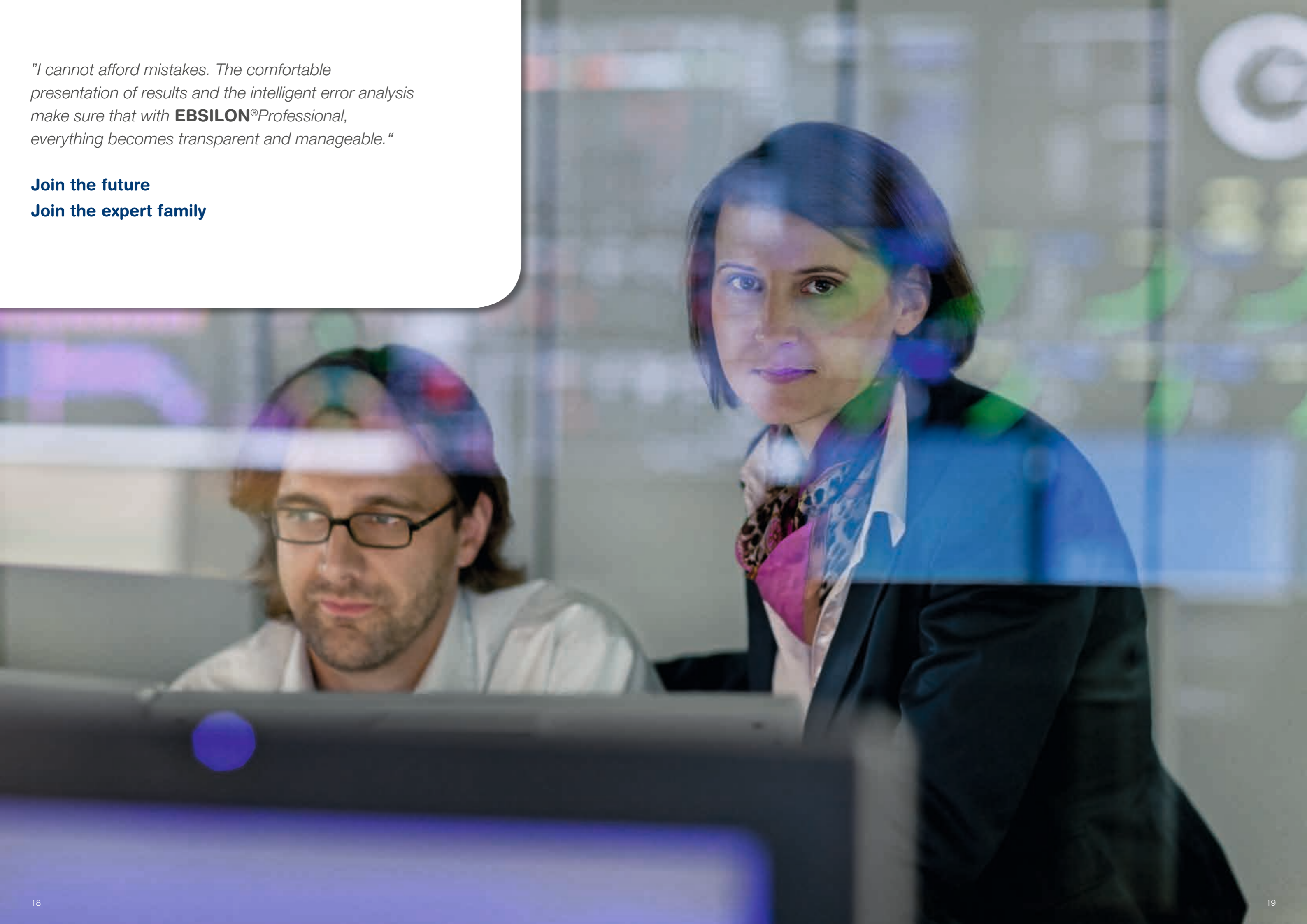



The Material Data Library – Working Fluids and Fuels

The material data library contains typical working fluids and fuels of power plant and energy technology. User-specific fluids can easily be defined by their chemical composition. For coal, a detailed database distinguished according to the extraction sites is integrated.

Fluids

- Water and steam
- Brine
- Humid air
- REFPROP library (NIST): Ninety fluids from acetone to xenon (two-phase)

- Thermal oils and molten salts
- Binary mixes: ammonia/ water, water/ lithium bromide
- Ideal and real gases
- Two-phase fluids
- User-defined fluids

Fuels

- Coal
- Oil
- Gas
- User-defined by composition

*"I need every freedom in planning. The open system architecture of **EBSILON**® Professional provides that. And the interfaces are really versatile and practice-oriented."*

Join the future
Join the expert family



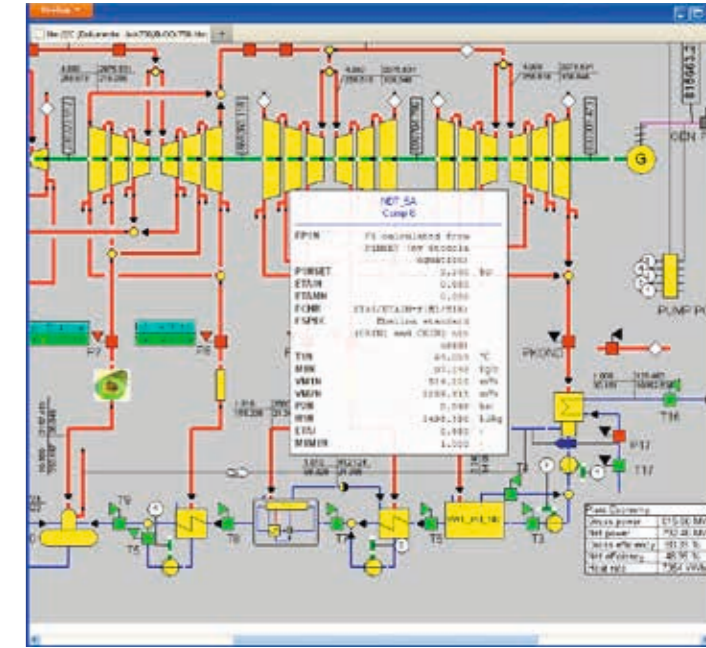
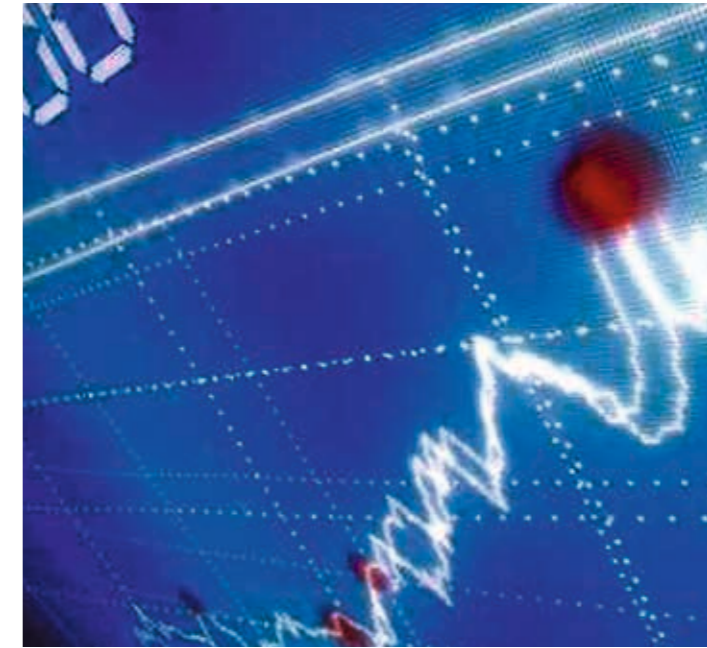

EbsBoiler – the Boiler in Detail

EbsBoiler contains components for the detailed modeling of boiler geometry and heat transfer. Thus you map the boiler close to reality, model specific boiler types, and determine the degree of fouling of individual heating surfaces.

- Components of EbsBoiler
- Flue gas zone
 - Reaction zone
 - Main heating surface
 - Auxiliary heating surface

EbsSolar – We Make the Sun Calculable

EbsSolar, developed in cooperation with the German Aerospace Center (DLR), contains components for the detailed dimensioning of a solar field. It is suited for investigations concerning site and technology as well as for annual output calculation.

Regarding the simulation of the storage system, direct and indirect storage components are available. The indirect storage calculates the temporally variable temperature field of the storage material. The direct storage allows the modeling e.g. of a two-tank liquid salt storage. Typical heat transfer fluids like thermal oil, liquid salt, and water/steam are stored in the material data library.

- Components of EbsSolar
- Solar collector (parabolic trough/linear Fresnel type)
 - Distributing header
 - Collecting header
 - Heliostat field
 - Solar tower (Receiver)

OEM-GTLib – the Gas Turbine Library

OEM-GTLib, developed in cooperation with and distributed by VTU Energy GmbH, contains a large number of gas turbine models. These are adjusted to the actual performance behavior and are based on official manufacturer data. Thus you select the optimal gas turbine for your power plant.

- Contains gas turbines from
- Siemens
 - Alstom
 - General Electric
 - Rolls Royce
 - MAN
 - Solar Turbines
 - Hitachi
 - Centrax

EbsOptimize – Parameter Optimization

EbsOptimize optimizes a target value by varying several influencing quantities. Thus the often laborious search for the optimal performance parameters of the plant is automated. Optimize the efficiency or fuel consumption of the plant while complying with all general technical requirements.

- The target value and influencing quantities can be freely formulated.
- Genetic algorithm
- Available as an EbsScript function

EbsValidate – Data Validation

EbsValidate adjusts the partially error-prone measured values of the numerous measuring points of your plant in such a way that all component equations are complied with. At the same time the error sum of squares is minimized. The result is the statistically most likely plant condition. Here the use of redundant measured data increases the statistical reliability of the validation result. Besides a quick validation, validation according to VDI 2048 is available, too.

- The offline validation with EbsValidate is suited
- for supporting acceptance tests, and
 - for identifying malfunctions in the measuring system and the components.

EbsHTML – Plant Model in the Web Browser

EbsHTML allows the output of the model including the simulation results in HTML format. The results for components and lines are displayed in a tool tip when the cursor is moved over them. Concerning the output you are free to decide which simulation results are to be displayed in the HTML file.

- Will display in all common internet browsers
- Various load cases and macros accessible
- Suitable for presenting the plant model without **EBSILON®Professional** license

Add-On Modules – Solutions from Power Plant Experts

Add-on modules expand the functionality of **EBSILON®Professional** and support your planning with the know-how of our experts.

EbsScript – Script Language for EBSILON®Professional

EbsScript is a PASCAL-based script language fully integrated in **EBSILON®Professional**.

With EbsScript, all processes in **EBSILON®Professional** can be automated and individual components can be programmed. In the course of this, there is full access to all data of the model, but also to external text and MS Excel files as well as the interfaces of **EBSILON®Professional**.

- Comfortable editor with browser-supported input
- Compiler with syntax check
- Integrated script management
- User-specific components programmable (component: kernel scripting)
- Usable for the automatic execution of case studies, optimizations, etc.

EbsOpen – COM Class Library

EbsOpen is a comprehensive COM class library that offers access to all application, model, and component data. It thus represents a powerful tool that allows the execution of simulation, validation, and what-if calculations, parameter studies as well as automated recalculations in power plant operation.

- More than 200 classes and 3,500 methods and properties
- Can be integrated into all common automation and programming environments like Visual Studio .Net or the VBA environment of the MS Office products

Open Software Architecture & Powerful Interfaces

Due to numerous interfaces, the software architecture of **EBSILON®Professional** allows easy integration into the existing software infrastructure and expansion by individual programs.

DLL interfaces

By means of Dynamic Link Libraries (DLL), data can be exchanged between other programs and **EBSILON®Professional**, and the calculation kernel can be expanded by individual components.

MS Excel interfaces

Simulation results as well as parameters and characteristics of individual components and lines can be exported and imported. It is possible to run simulations directly from the Excel worksheet using the MS Excel add-in for **EBSILON®Professional**.

COM interface EbsOpen

EbsOpen can be integrated into all common automation and programming environments like e.g. Visual Studio .Net for direct programming with Visual Basic or C++ as well as the VBA environments of the MS Office products.

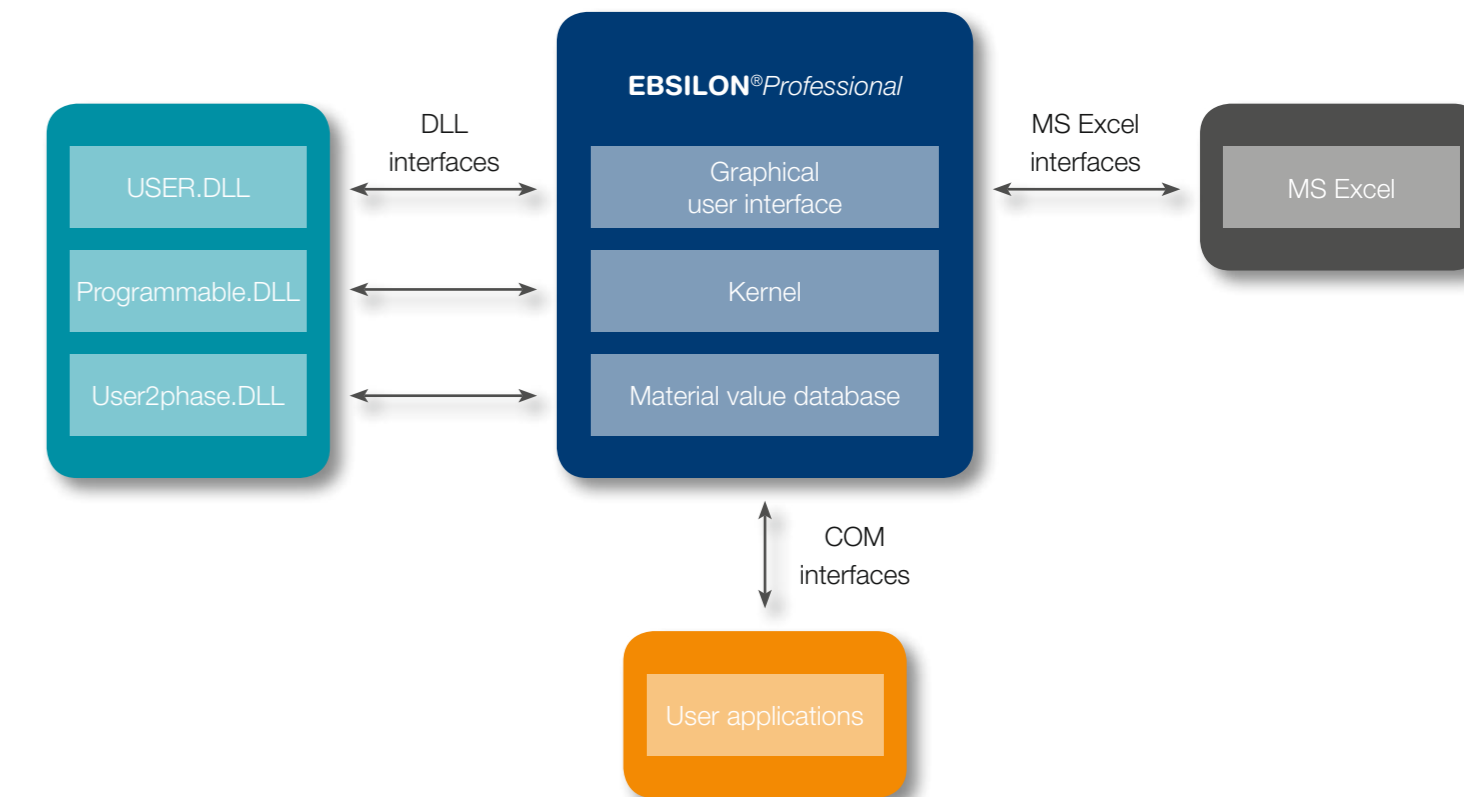

*"For me as a planner of solar power plants, **EBSILON**®Professional offers the proper component library. That speaks for itself. Besides, the future of the power plant industry will be so diverse that integrated solutions and innovative concepts are becoming more and more important. **EBSILON**®Professional is the program that can do that."*

Join the future
Join the expert family





User conference at the Dorint Pallas Hotel, Wiesbaden

Services

Know-how for your Company

Improve your modeling expertise. We offer training courses for **EBSILON®Professional** and its add-on modules from beginner to expert level; these are run by experienced project engineers.

Workshops

Together with you, our engineers compile your individual plant model and answer all questions that may come up in the process of modeling.

Your Contact Persons

Expertise and Customer Service since 1990

The branch in Zwingenberg (Hessen, Germany) is responsible for the development, distribution, and support of **EBSILON®Professional**. This is also where staff training and the annual user conferences take place.

With more than 150 customers, **EBSILON®Professional** is represented worldwide. Among them are international groups, medium-sized engineering offices as well as research and teaching institutions, which emphasizes the varied range of application as well as the flexibility and easy handling of **EBSILON®Professional**. The dialog with our customers and the expertise of our developers and cooperation partners from industry and top level research will continue to ensure our common success.



Peter Krüger
Director
System Technologies



Renate Kunert
Assistant



Detlef Günzel
Sales



Dr. Reiner Pawellek
Development
Manager



Dr. Tobias Löw
Architect and
Lead Developer

*"The trickier the task, the more you will appreciate **EBSILON**®Professional. And if there is an issue I'll just call Support and send in my planning file. I don't know any other software with such a good and fast support. You feel like in a real family of experts."*

Join the future
Join the expert family





References Worldwide

- ABB
- Alstom
- Areva Renouvelables
- BMW
- BWSC Denmark
- Colenco Power Engineering
- E.ON
- EnBW
- Enertech
- Envi Con & Plant Engineering
- FISIA BABCOCK Environment
- General Electric
- giz China/India
- Hitachi Power Europe

- Infracor
- ISKEN A.Ş.
- J-Power Japan
- Kraftanlagen München
- Mainova
- MAN
- Mitsubishi Turkey
- MVV Energy
- NEM
- Pöyry
- Public utilities
 - Chemnitz
 - Kassel
 - Halle

- Munich
- Hannover
- RMD Consult
- RWE
- SEPCO III
- Standardkessel
- TÜV Nord
- Vattenfall
- VA Tech Hydro
- Wärtsilä Finland
- VTU Energy
- DLR German Aerospace Center
- Central Power Research Institute India

- Chalmers University of Technology Goteborg
- Institute of Technology Karlsruhe
- Politechnika Śląska Giwice
- RWTH Aachen
- TU Darmstadt
- TU Berlin
- TU München
- TU Vienna
- University Duisburg-Essen
- University of Applied Sciences Zittau/Görlitz
- University Stuttgart

STEAG Energy Services GmbH
System Technologies

Wetzbach 35

64673 Zwingenberg, Germany

Phone +49 6251 1059-0

Fax +49 6251 1059-29

www.ebsilon.com

www.steag-systemtechnologies.com

steag